

REVISIONS			
REV	DESCRIPTION	DATE	APPROVED
00	INITIAL RELEASE	5/7/09	R.T
01	ADD TAB ON 4 CORNER EPAD	3/3/10	R.T
02	ADD OPTION E2/D2: 5.3MM SQ.	2/23/11	OK LEE
03	ADD EPAD OPTION TABLE	12/10/12	RC
04	COMBINE POD & LAND PATTERN	8/14/13	KS

EVEN LEAD SIDES

ODD LEAD SIDES

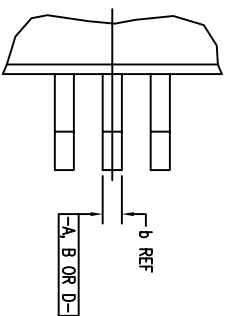
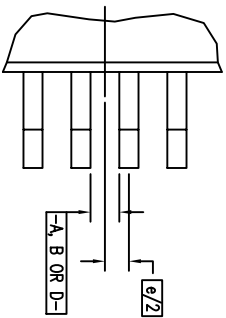

DETAIL A

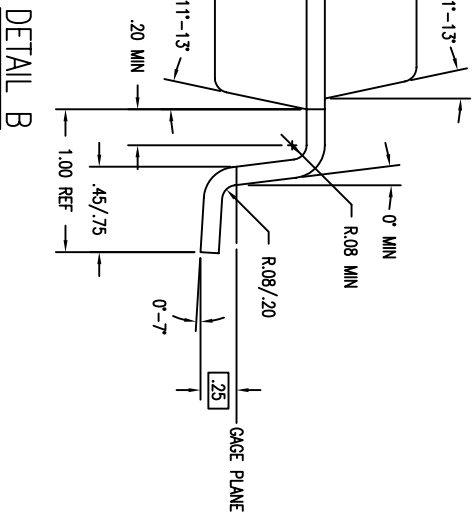
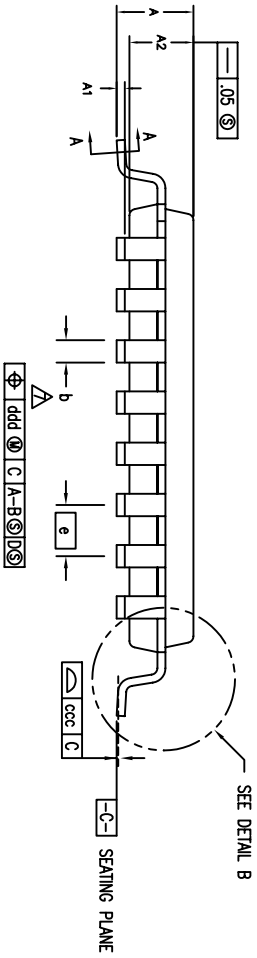
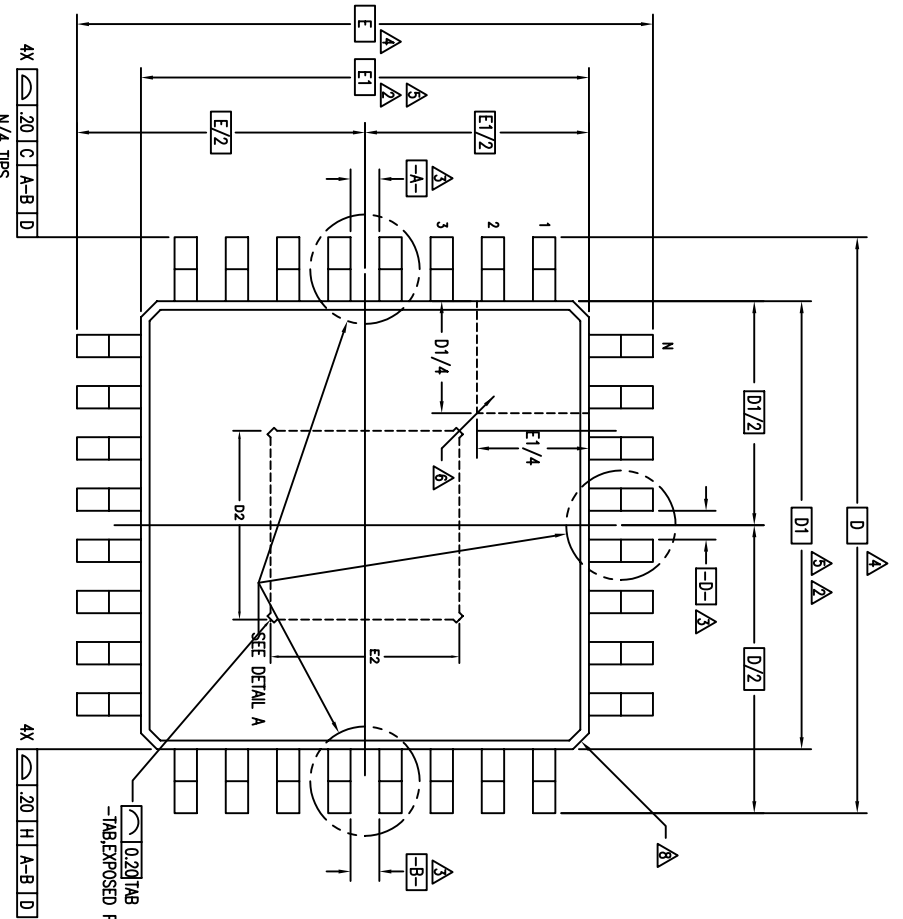

DETAIL B

SECTION A-A

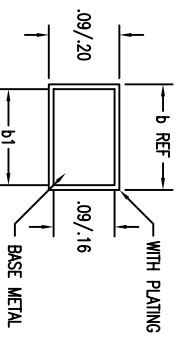

TOLERANCES UNLESS SPECIFIED	
DECIMAL	±
ANGULAR	±
XXX±	
XXXX±	
XXXX±	
APPROVALS	DATE
DRAWN	02/05/09
CHECKED	
SIZE	DRAWING No.
C	PSC-4251
DO NOT SCALE DRAWING	SHEET 1 OF 3

**IDT**  
 8024 Silver Creek Valley Rd  
 San Jose, CA 95138  
 PHONE: (408) 284-8200  
 FAX: (408) 284-3572  
 WWW.IDT.COM

TITLE: DX/DXG48 PACKAGE OUTLINE  
 7.0 X 7.0 X 1.0 mm TOPP  
 1.00/.10 FORM

REV	DESCRIPTION
04	

REVISIONS			
REV	DESCRIPTION	DATE	APPROVED
00	INITIAL RELEASE	5/7/09	R.T
01	ADD TAB ON 4 CORNER EPAD	3/3/10	R.T
02	ADD OPTION E2/D2: 5.3MM SQ.	2/23/11	CK LEE
03	ADD EPAD OPTION TABLE	12/10/12	RC
04	COMBINE POD & LAND PATTERN	8/14/13	KS

EPAD OPTION:

Symbol	P1			P2			P3		
	MIN	NOM	MAX	MIN	NOM	MAX	MIN	NOM	MAX
D2	2.85	2.95	3.05	3.40	3.50	3.60	5.20	5.30	5.40
E2	2.85	2.95	3.05	3.40	3.50	3.60	5.20	5.30	5.40

NOTES:

- 1 ALL DIMENSIONING AND TOLERANCING CONFORM TO ANSI Y14.5M-1982
- TOP PACKAGE MAY BE SMALLER THAN BOTTOM PACKAGE BY .15 mm
- DATUMS [A-B] AND [D-] TO BE DETERMINED AT DATUM PLANE [H-]
- DIMENSIONS D AND E ARE TO BE DETERMINED AT SEATING PLANE [C-]
- DIMENSIONS D1 AND E1 DO NOT INCLUDE MOLD PROTRUSION. ALLOWABLE MOLD PROTRUSION IS .25 mm PER SIDE. D1 AND E1 ARE MAXIMUM BODY SIZE DIMENSIONS INCLUDING MOLD MISMATCH
- DETAILS OF PIN 1 IDENTIFIER IS OPTIONAL BUT MUST BE LOCATED WITHIN THE ZONE INDICATED
- DIMENSION b DOES NOT INCLUDE DAMBAR PROTRUSION. ALLOWABLE DAMBAR PROTRUSION IS .08 mm IN EXCESS OF THE b DIMENSION AT MAXIMUM MATERIAL CONDITION. DAMBAR CANNOT BE LOCATED ON THE LOWER RADIUS OR THE FOOT.
- EXACT SHAPE OF EACH CORNER IS OPTIONAL
- THESE DIMENSIONS APPLY TO THE FLAT SECTION OF THE LEAD BETWEEN .10 AND .25 mm FROM THE LEAD TIP
- ALL DIMENSIONS ARE IN MILLIMETERS
- THIS OUTLINE CONFORMS TO JEDEC PUBLICATION 95 REGISTRATION MS-026, VARIATIONS BBA & BBC.

SYMBOL	JEDEC VARIATION			NOTE
	MIN	NOM	MAX	
A	-	-	1.20	
A1	.05	.10	.15	
A2	0.95	1.00	1.05	
D		9.00 BSC		4
D1		7.00 BSC		5,2
E		9.00 BSC		4
E1		7.00 BSC		5,2
N		48		
e		.50 BSC		
E2		SEE EPAD OPTION		
D2		SEE EPAD OPTION		
b	.17	.22	.27	7
b1	.17	.20	.23	
ccc	-	-	.08	
ddd	-	-	.08	

<b>TOLERANCES</b> UNLESS SPECIFIED DECIMAL ± ANGULAR ± XXXX XXXX APPROVALS DATE DRAWN 08/09/09 CHECKED		 6024 Silver Creek Valley Rd San Jose, CA 95138 PHONE: (408) 284-8200 FAX: (408) 284-3572 www.IDT.com	
TITLE DX/DXG48 PACKAGE OUTLINE 7.0 X 7.0 X 1.0 mm TQFP 1.00/.10 FORM		SIZE C DRAWING No. PSC-4251	REV 04 SHEET 2 OF 3

REVISIONS			
REV	DESCRIPTION	DATE	APPROVED
00	INITIAL RELEASE	5/7/09	R.T
01	ADD TAB ON 4 CORNER EPAD	3/3/10	R.T
02	ADD OPTION E2/D2: 5.3MM SQ.	2/23/11	CK LEE
03	ADD EPAD OPTION TABLE	12/10/12	RC
04	COMBINE POD & LAND PATTERN	8/14/13	KS

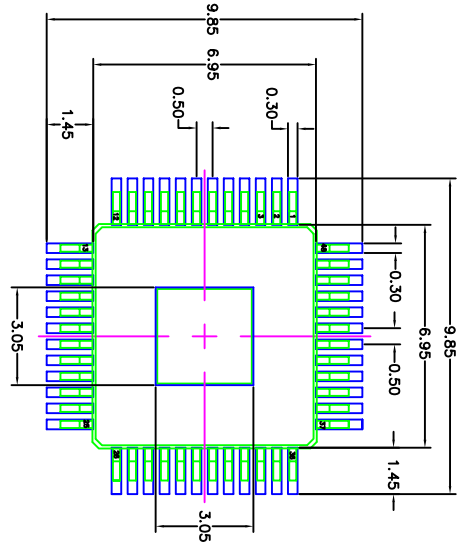

EPAD 2.95mm SQ

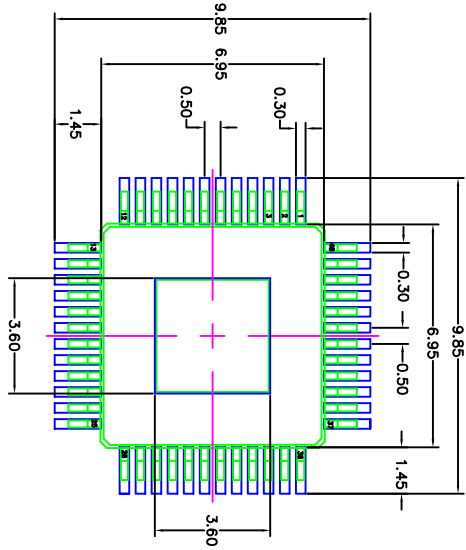

EPAD 3.50mm SQ

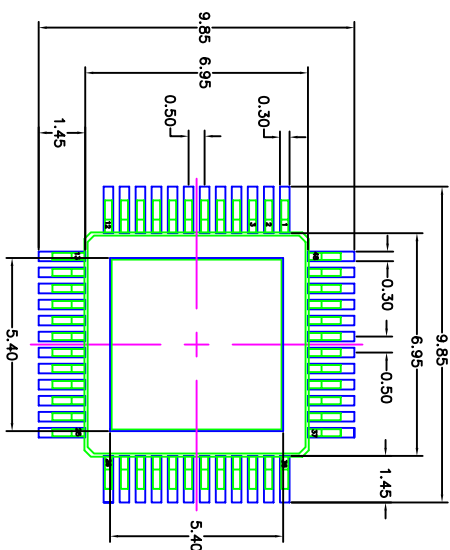

EPAD 5.30mm SQ

- NOTES:
1. ALL DIMENSION ARE IN mm. ANGLES IN DEGREES.
  2. TOP DOWN VIEW. AS VIEWED ON PCB.
  3. COMPONENT OUTLINE SHOW FOR REFERENCE IN GREEN.
  4. LAND PATTERN IN BLUE. NSMD PATTERN ASSUMED.
  5. LAND PATTERN RECOMMENDATION PER IPC-7351B GENERIC REQUIREMENT FOR SURFACE MOUNT DESIGN AND LAND PATTERN.

TOLERANCES UNLESS SPECIFIED		DECIMAL ANGULAR	
XXXX		±	
APPROVALS		DATE	TITLE
DRAWN		08/15/7/09	DX/DXG48 PACKAGE OUTLINE
CHECKED			7.0 X 7.0 X 1.0 mm TOP
			1.00/.10 FORM
SIZE		DRAWING No.	REV
C		PSC-4251	04
DO NOT SCALE DRAWING			
SHEET 3 OF 3			

6024 Silver Creek Valley Rd  
San Jose, CA 95138  
PHONE: (408) 284-8200  
FAX: (408) 284-3572

WWW.IDT.COM